

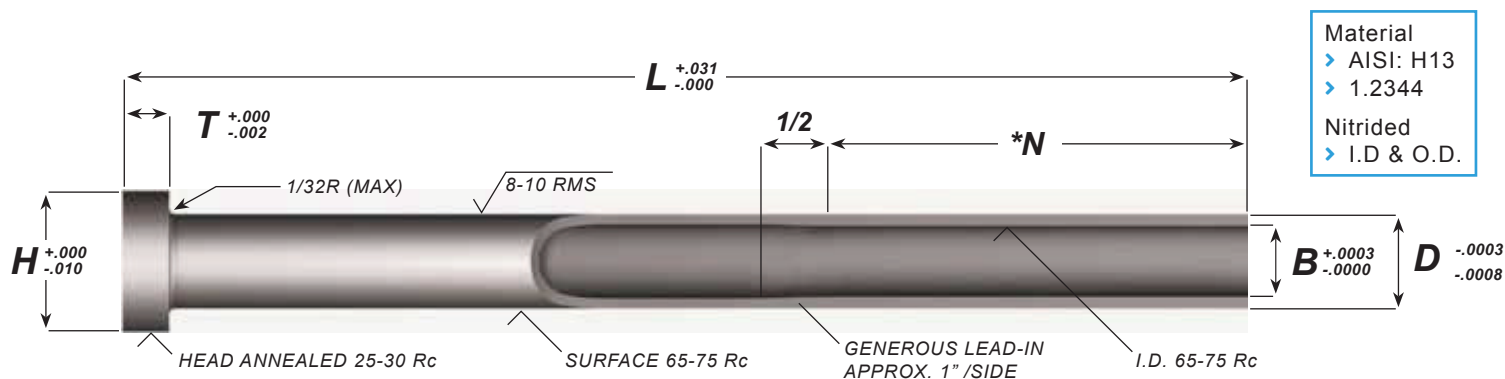

# EJECTOR SLEEVES — +.005 OVERSIZE

NITRIDED — PARALLEL — INCH



B I.D.	D O.D.	Cat. No.	L									H	T
			4"	5"	6"	7"	8"	9"	10"	11"	12"		
3/32	0.193	<b>OSE02</b>	L04	L05	L06	L07	L08	L09	L10	L11	L12	3/8	3/16
1/8	0.224	<b>OSE03</b>	L04	L05	L06	L07	L08	L09	L10	L11	L12	13/32	3/16
5/32	0.255	<b>OSE04</b>	L04	L05	L06	L07	L08	L09	L10	L11	L12	7/16	3/16
3/16	0.318	<b>OSE05</b>	L04	L05	L06	L07	L08	L09	L10	L11	L12	1/2	1/4
1/4	0.380	<b>OSE06</b>	L04	L05	L06	L07	L08	L09	L10	L11	L12	5/8	1/4
5/16	0.443	<b>OSE07</b>	L04	L05	L06	L07	L08	L09	L10	L11	L12	11/16	1/4
3/8	0.505	<b>OSE08</b>	L04	L05	L06	L07	L08	L09	L10	L11	L12	3/4	1/4

- > To order, add overall length "L" to Catalog Number. Example: OSE02L04
- > Sizes marked in light print are available but generally not stocked. Call for price and delivery. Example: OSE02L11  
 \*(N) = 1-3/4 for OSE02 and OSE03  
 \*(N) = 2-1/4 for OSE04 and larger
- > Any of DMS standard sleeves (from page B9) can be ordered oversize. Call our order desk for details.